

Name _____

Problem Solving Recording Sheet

Problem:

MAKE SENSE OF THE PROBLEM

Need to Find

Given

PERSEVERE IN SOLVING THE PROBLEM

Some Ways to Represent Problems

- Draw a Picture
- Make a Bar Diagram
- Make a Table or Graph
- Write an Equation

Some Math Tools

- Objects
- Grid Paper
- Rulers
- Technology
- Paper and Pencil

Solution and Answer

CHECK THE ANSWER

Name _____

Date _____

Dear Family,

Your student has just completed Topic _____ in our math program.

Teacher Comments:



Name of student: _____

I have received and reviewed this progress report for my student.

Parent/Guardian Signature

Parent/Guardian Comments:

Name _____











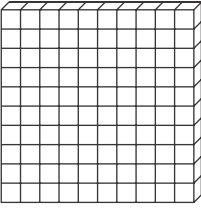
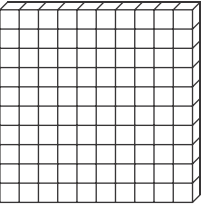
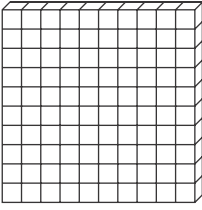
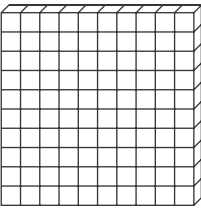
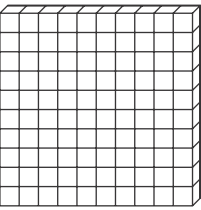
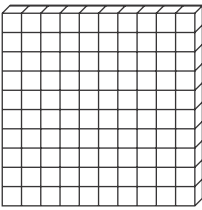
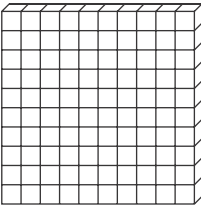
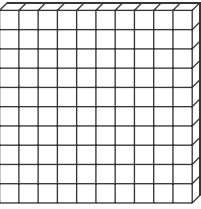
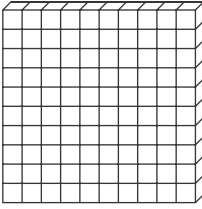

































Place-Value Chart 1

billions			millions			thousands			ones		
hundred billions	ten billions	billions	hundred millions	ten millions	millions	hundred thousands	ten thousands	thousands	hundreds	tens	ones

Place-Value Chart 2

billions			millions			thousands			ones		
hundred billions	ten billions	billions	hundred millions	ten millions	millions	hundred thousands	ten thousands	thousands	hundreds	tens	ones

Name _____

Name _____

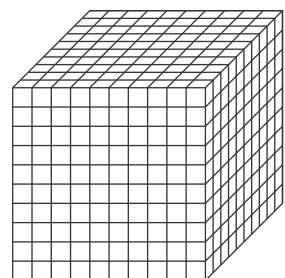
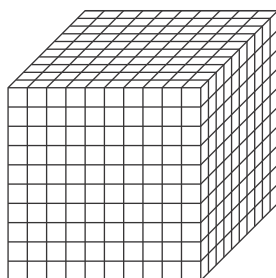
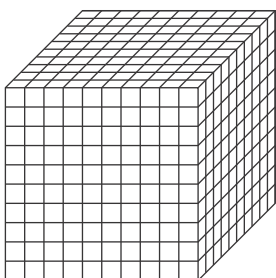
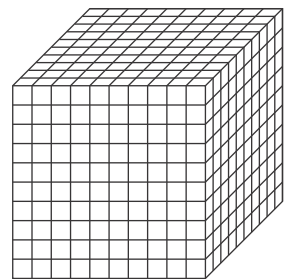
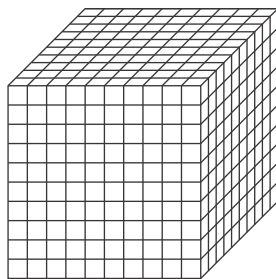
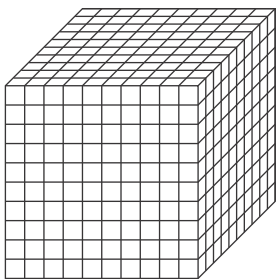
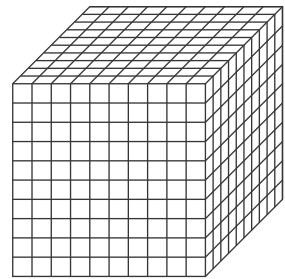
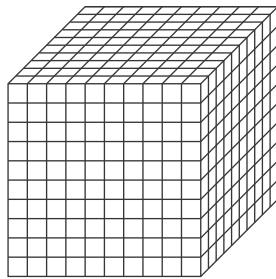
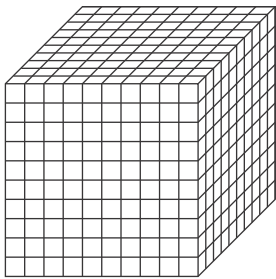
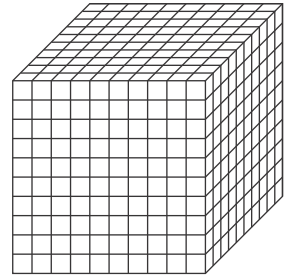
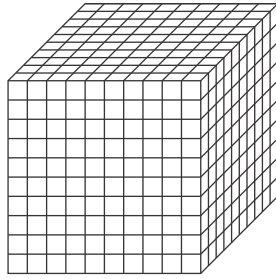
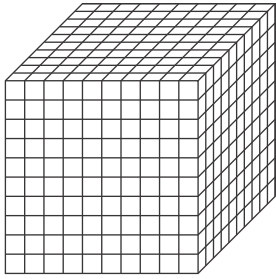

Name _____

hundreds			tenths		
tens	ones	ones	tenths	hundredths	thousandths
			•		
			•		
			•		
			•		
			•		

hundreds			tenths		
tens	ones	ones	tenths	hundredths	thousandths
			•		
			•		
			•		
			•		
			•		

hundreds			tenths		
tens	ones	ones	tenths	hundredths	thousandths
			•		
			•		
			•		
			•		
			•		

hundreds			tenths		
tens	ones	ones	tenths	hundredths	thousandths
			•		
			•		
			•		
			•		
			•		

Name _____

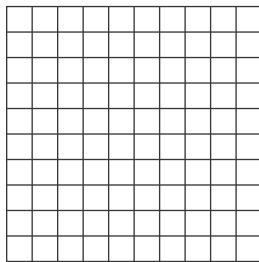
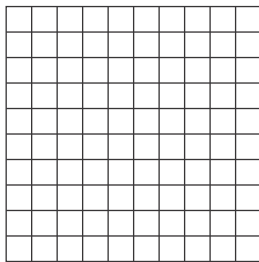
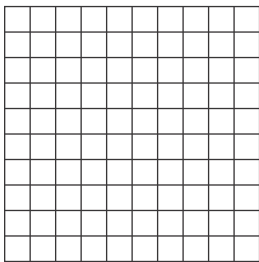
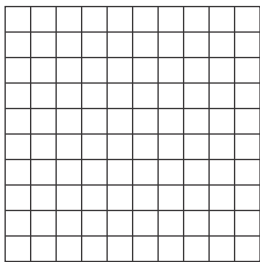
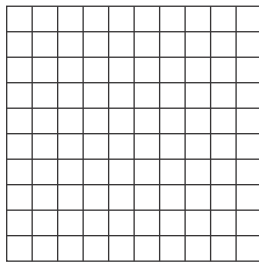
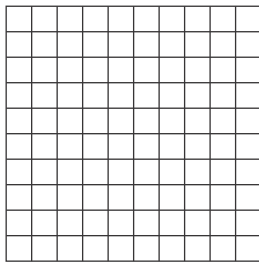
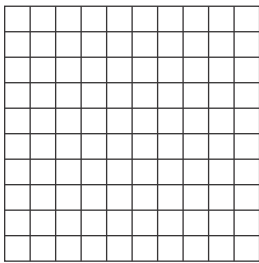
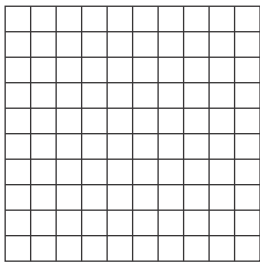
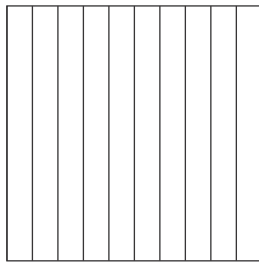
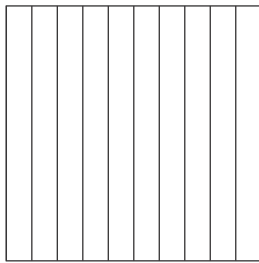
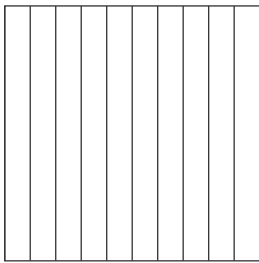
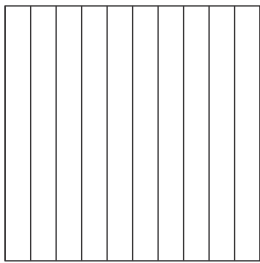
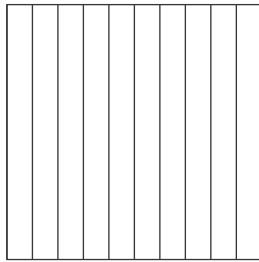
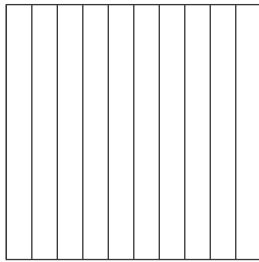
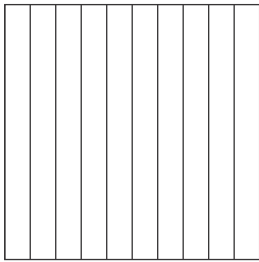
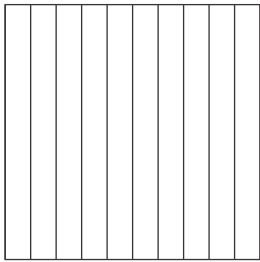
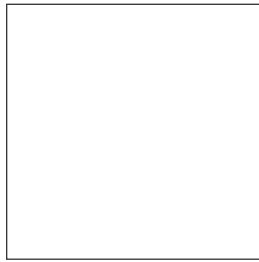
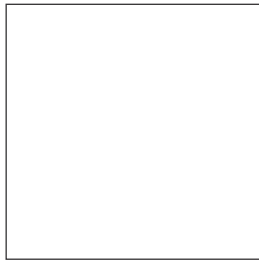
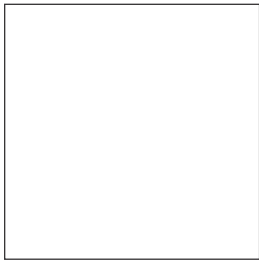
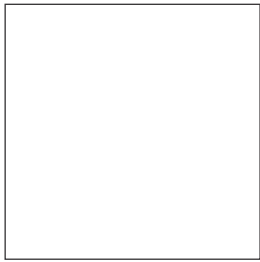

Name _____

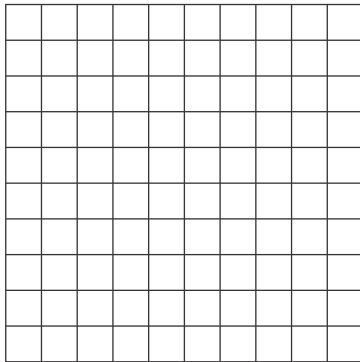
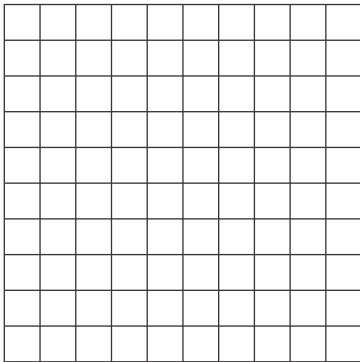
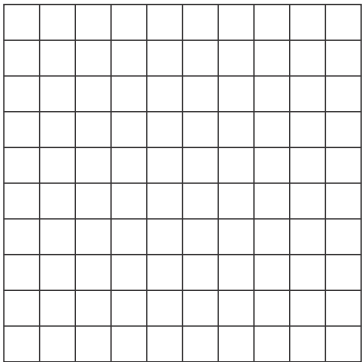
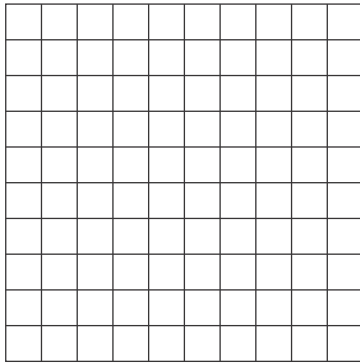
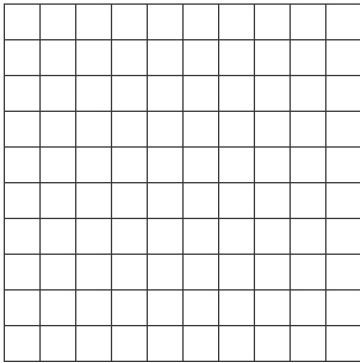
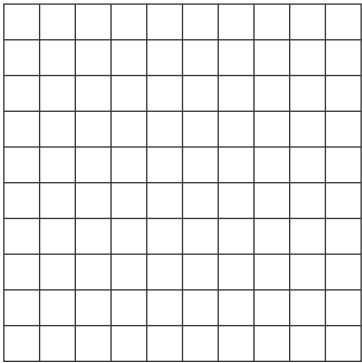
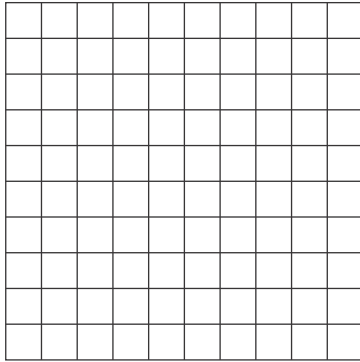
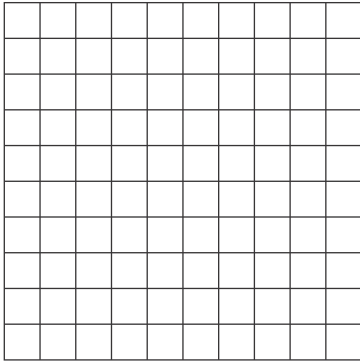
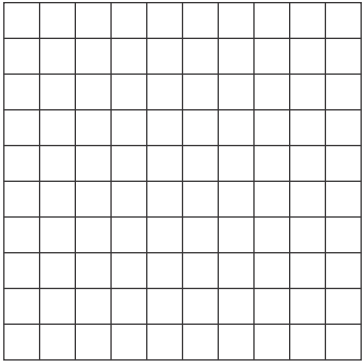
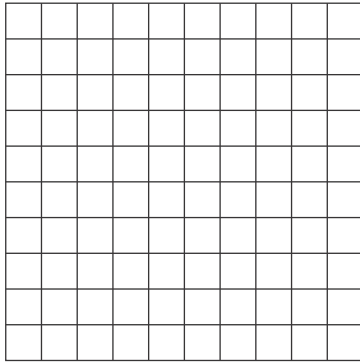
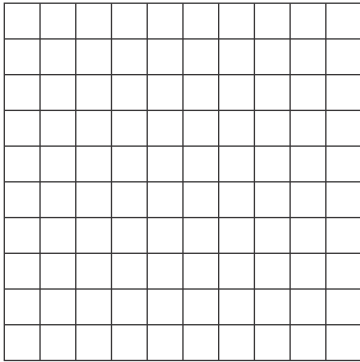
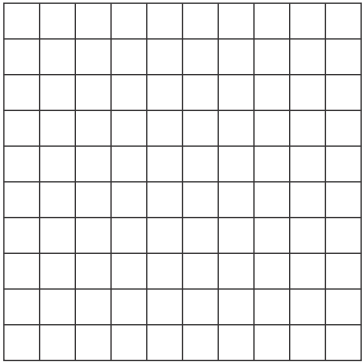

Name _____

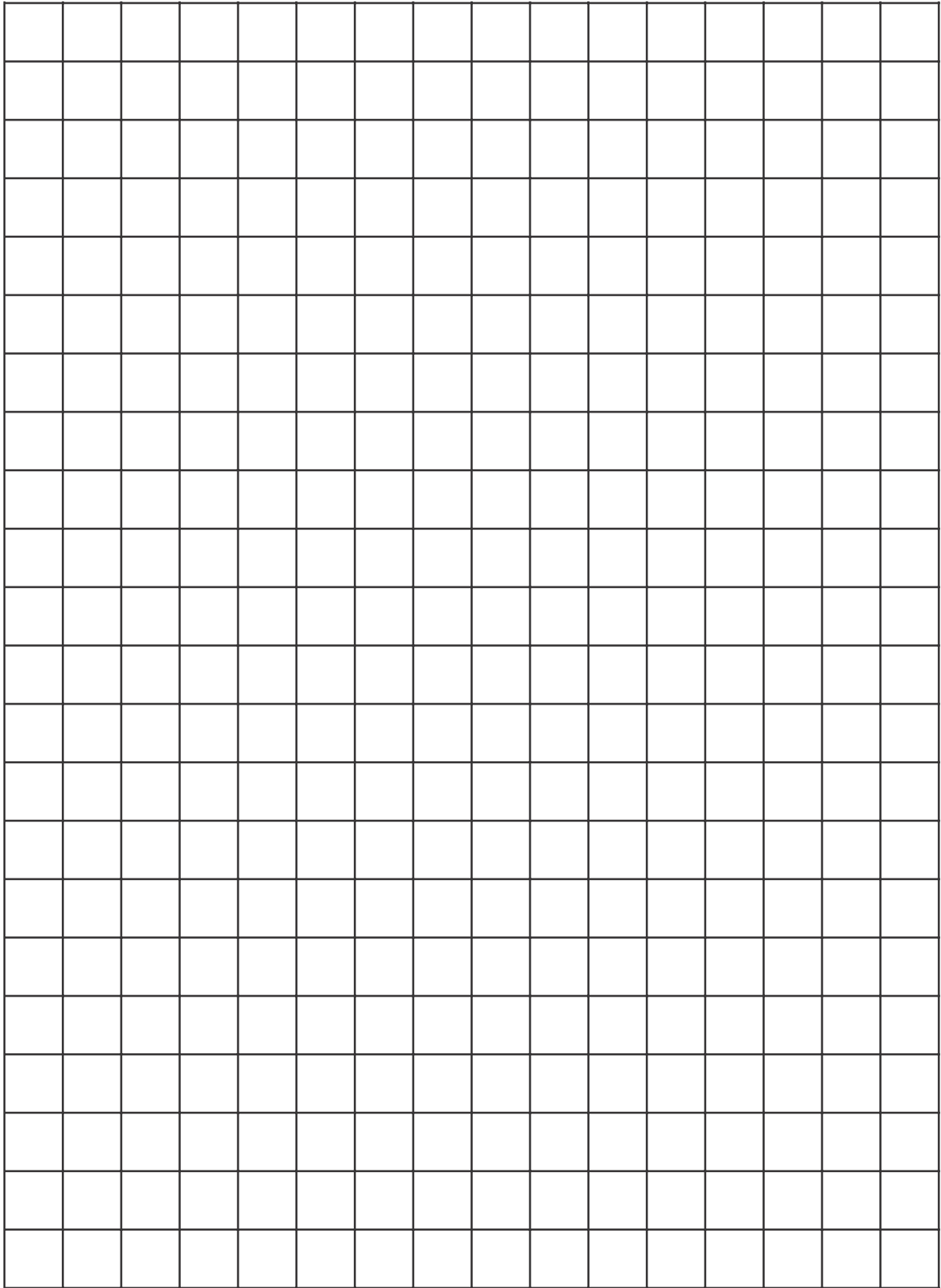

Name _____

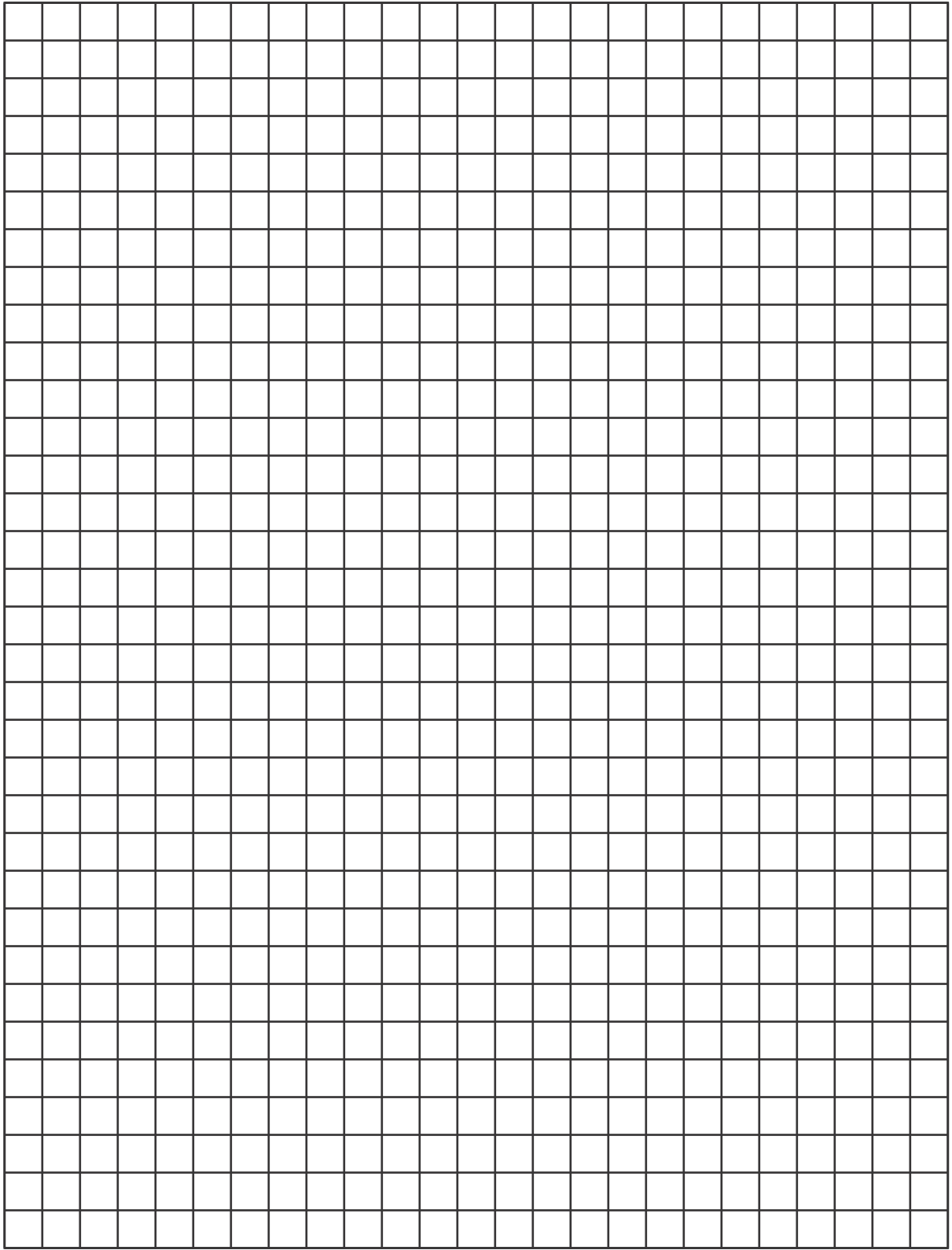

Name _____

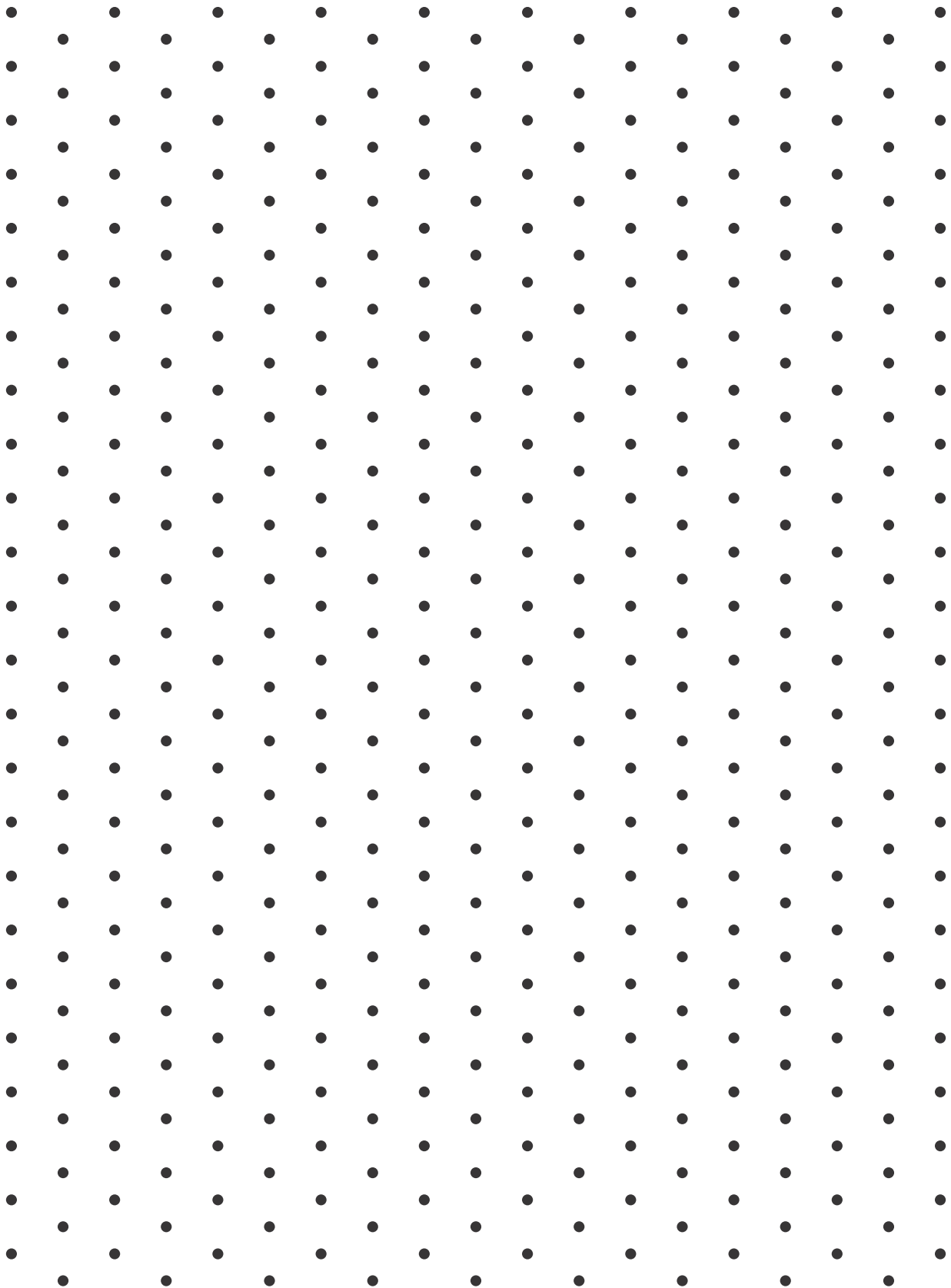

Name _____

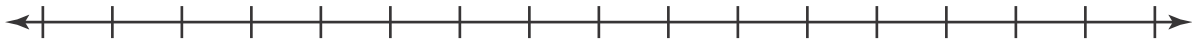

Name _____

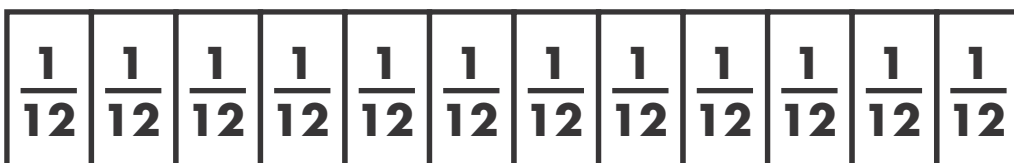
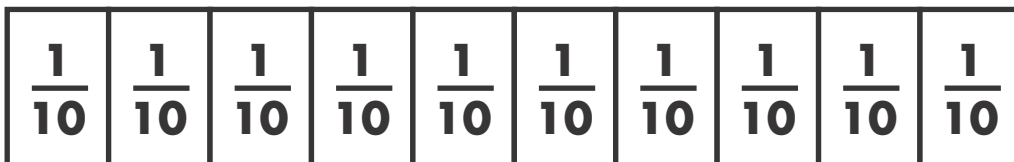
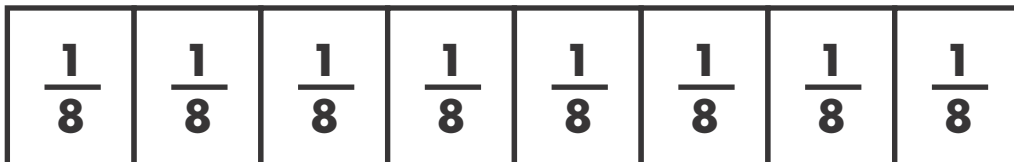
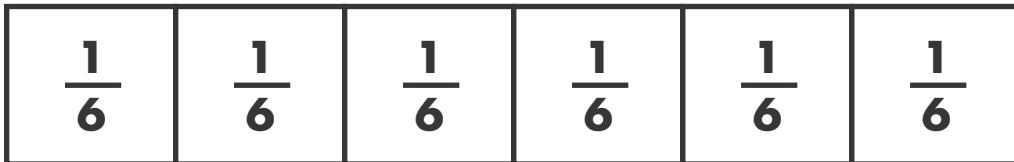
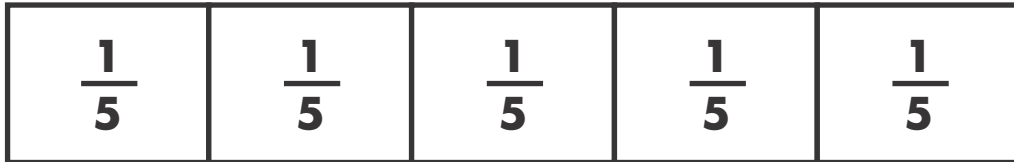
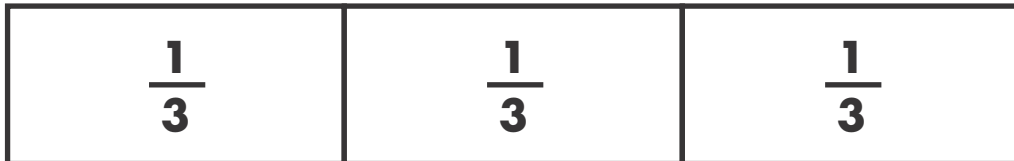

Name _____

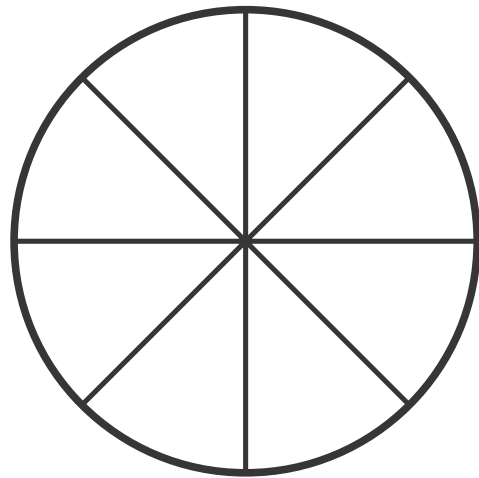
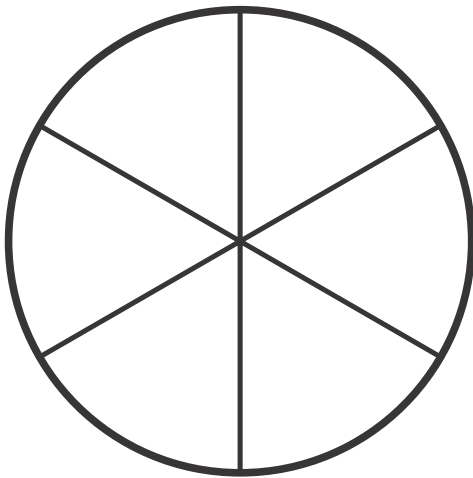
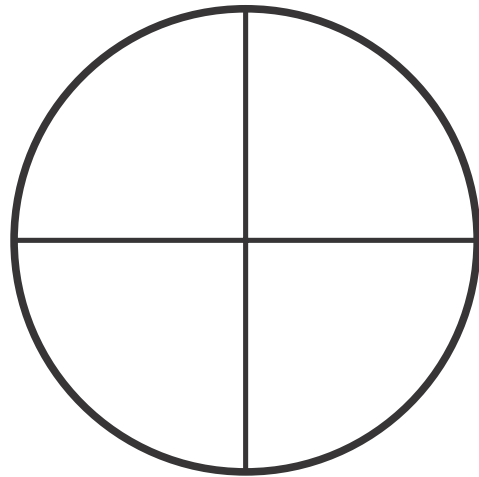
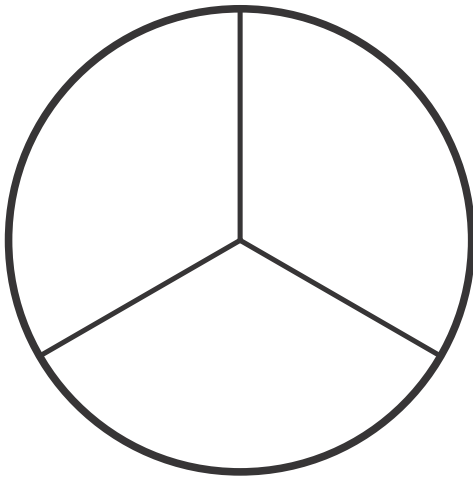
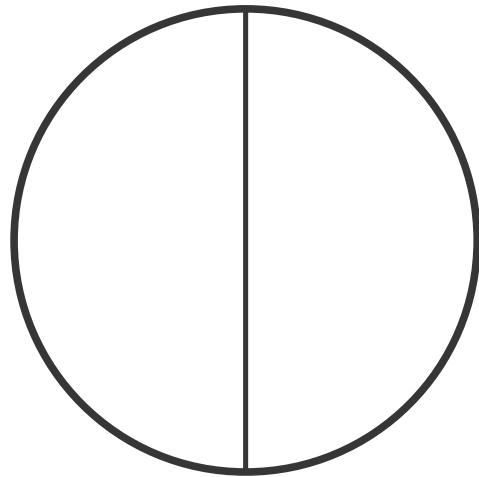
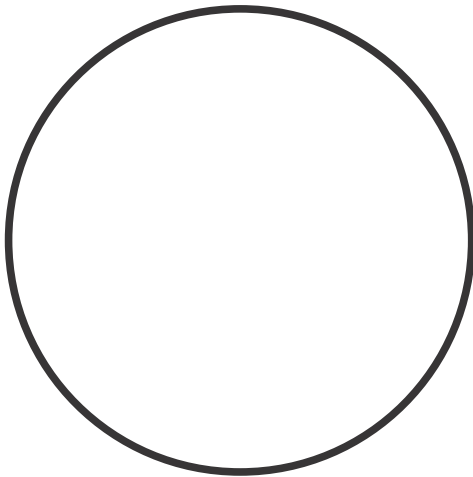

Name _____

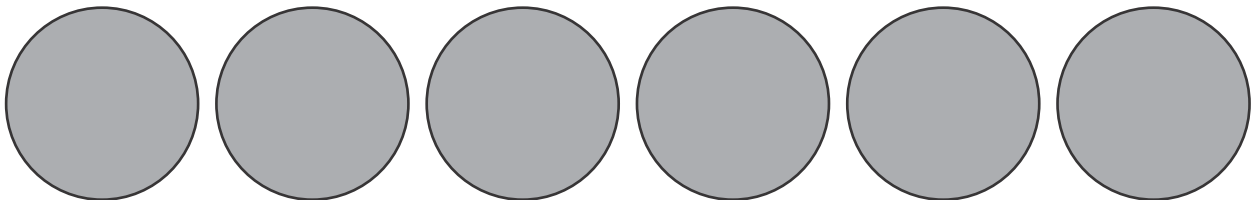
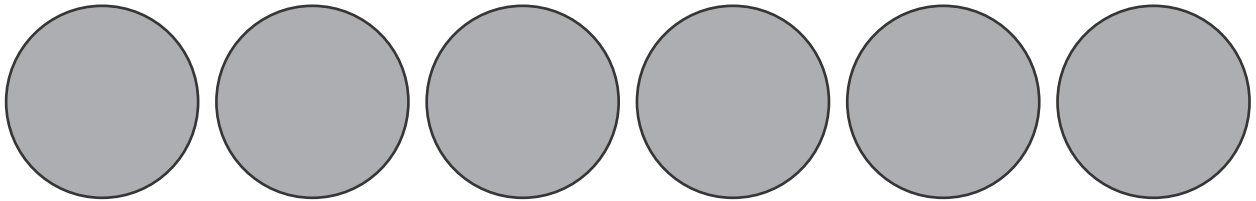
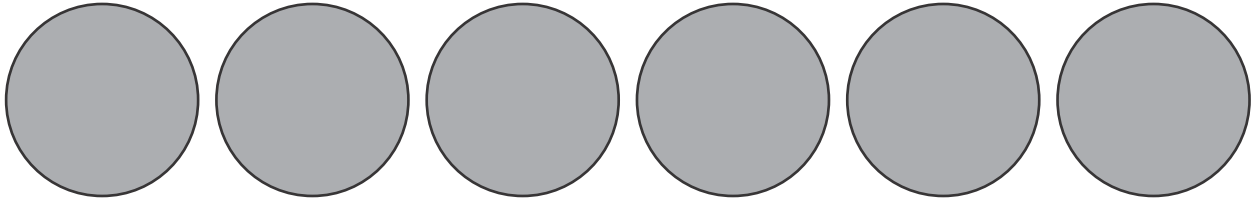
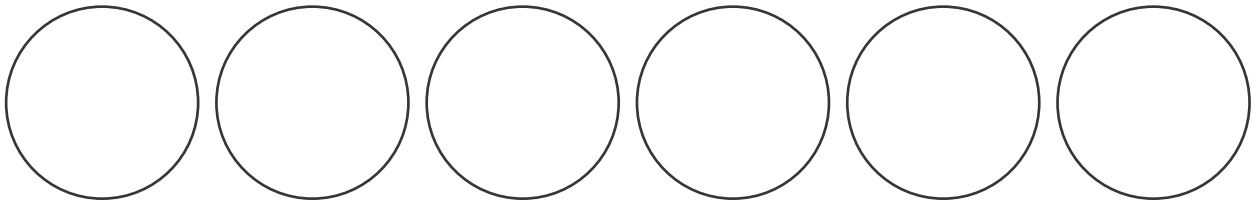
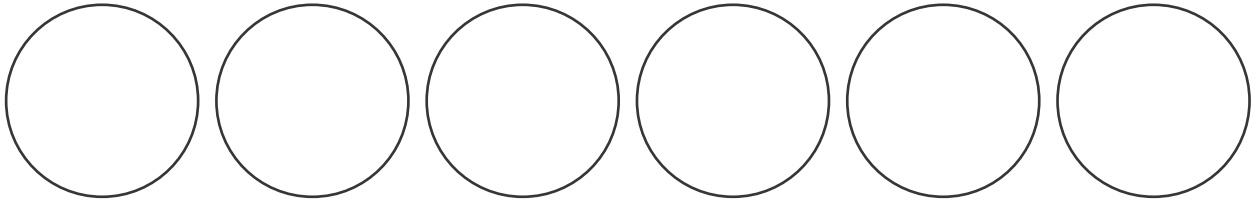
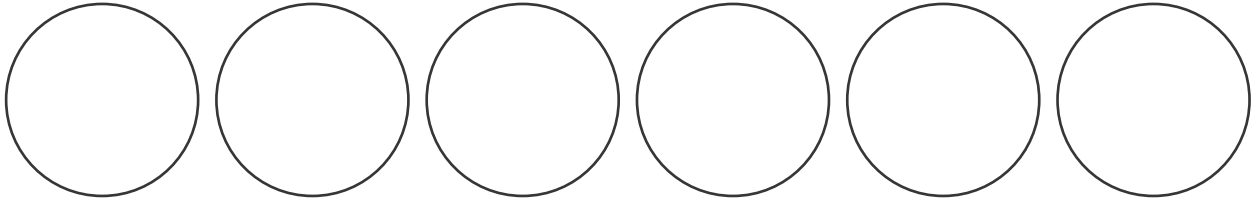

Name _____

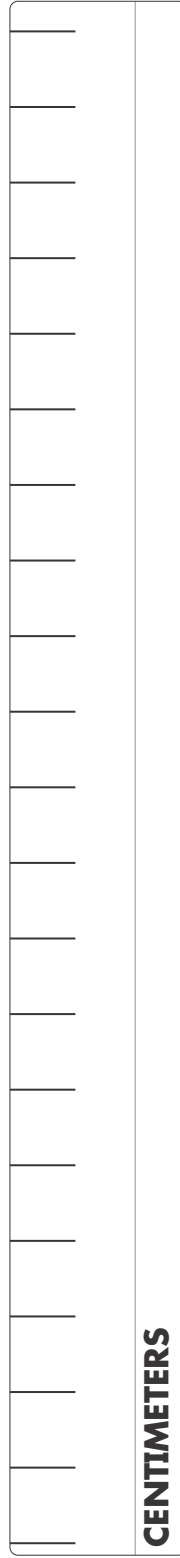
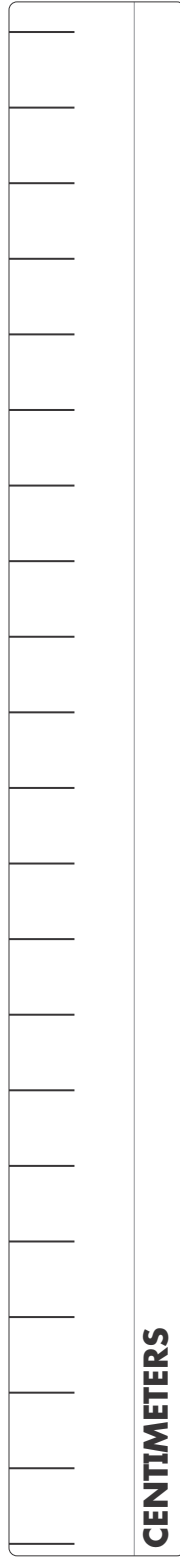
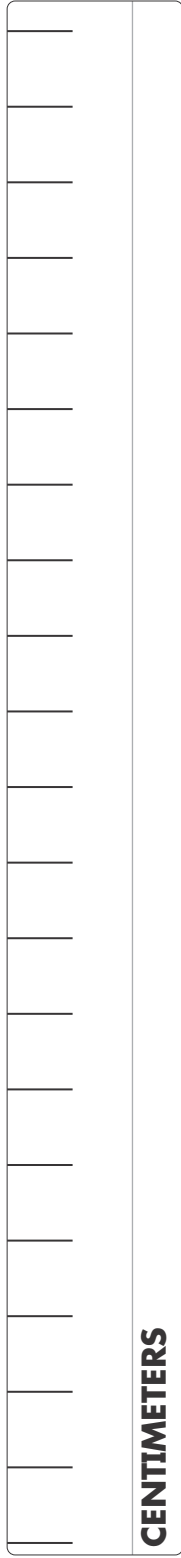
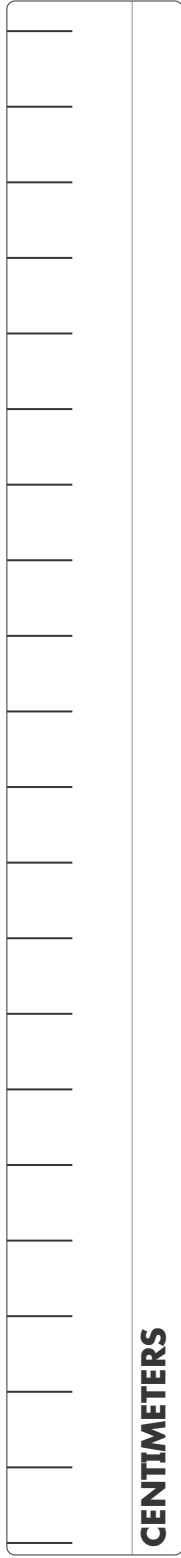
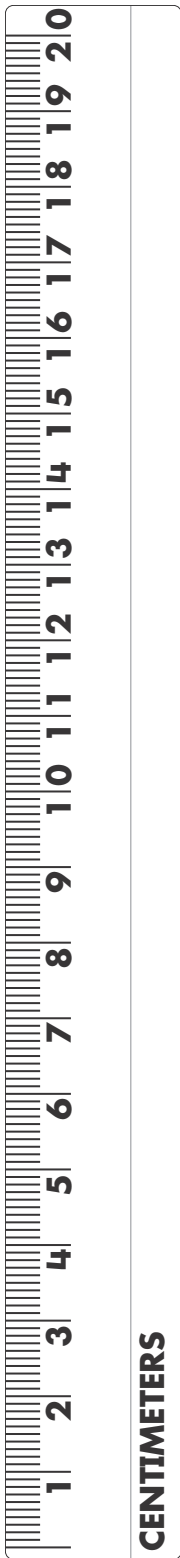

(To form a meterstick, cut out and tape five rulers together and complete labeling.)

Name _____

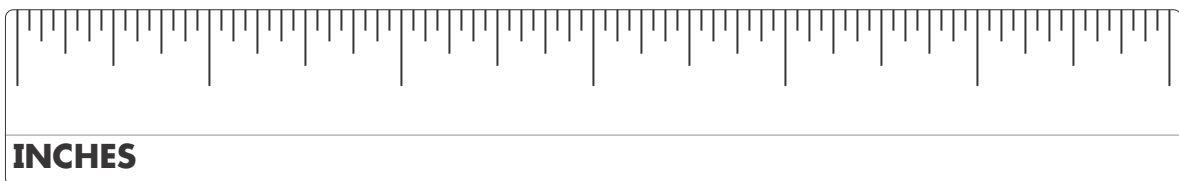
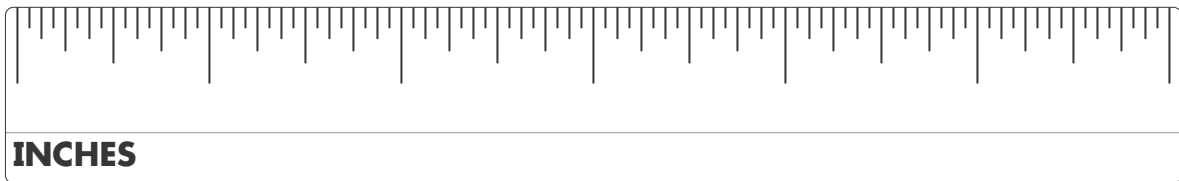
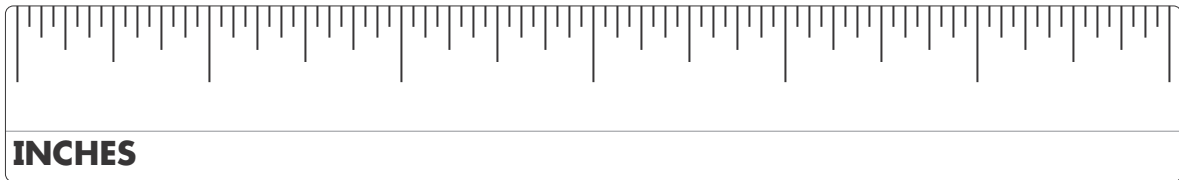
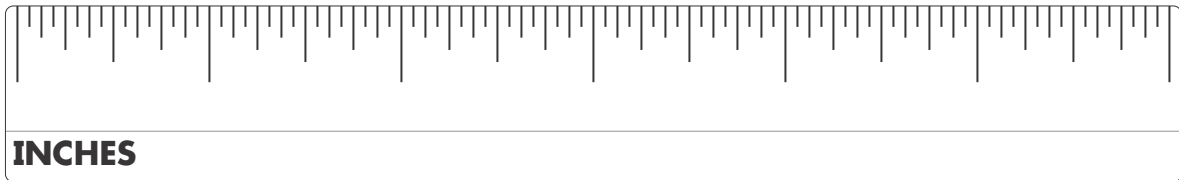
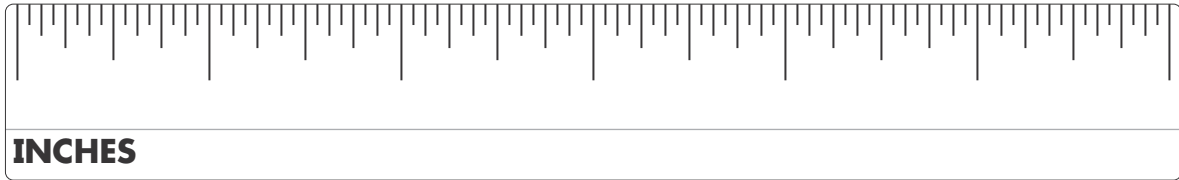
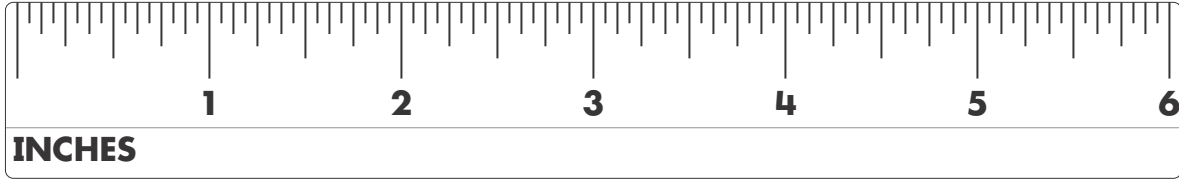

(To form a yardstick, cut out and tape six rulers together and complete labeling.)



Name _____

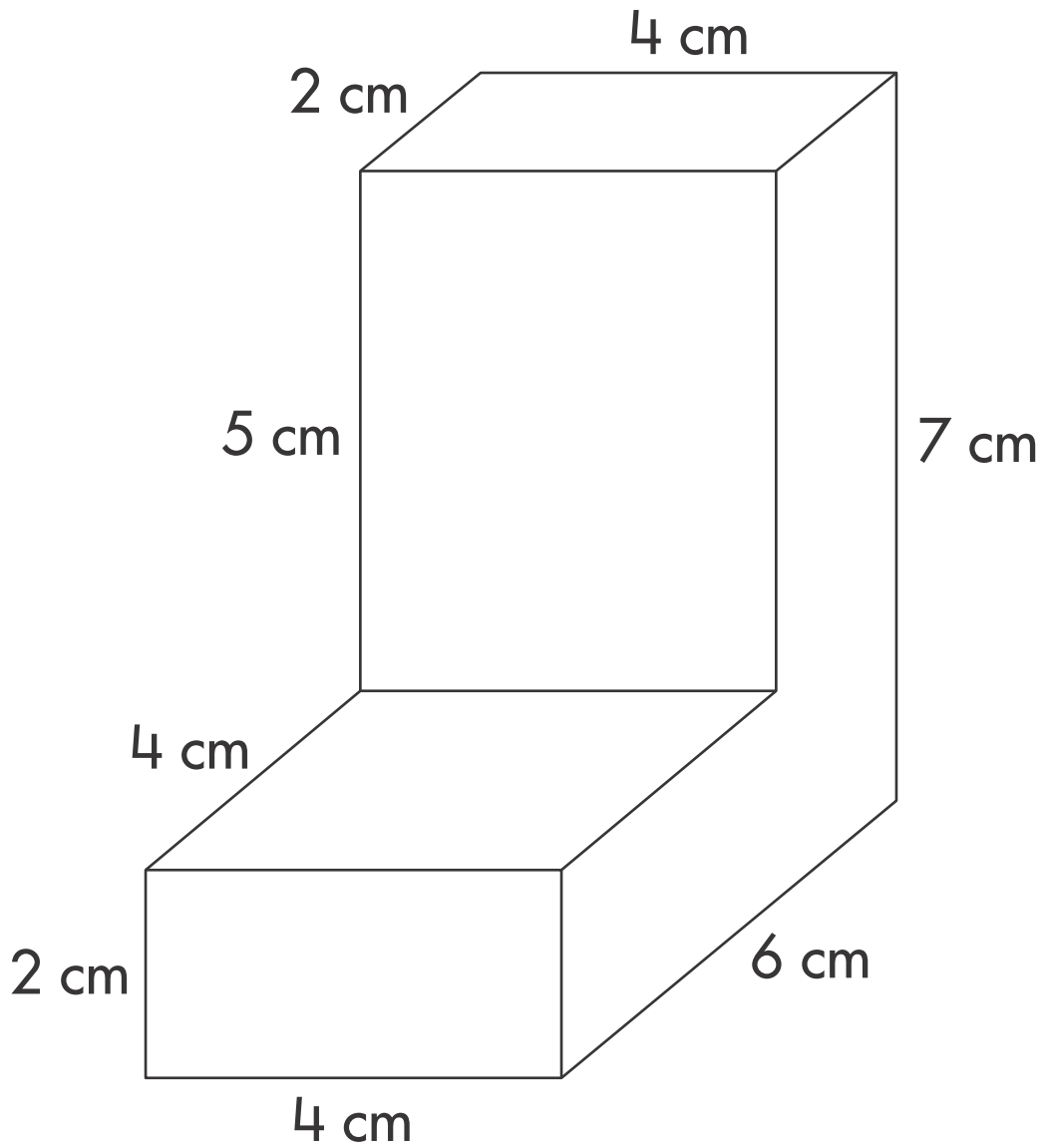

Name _____

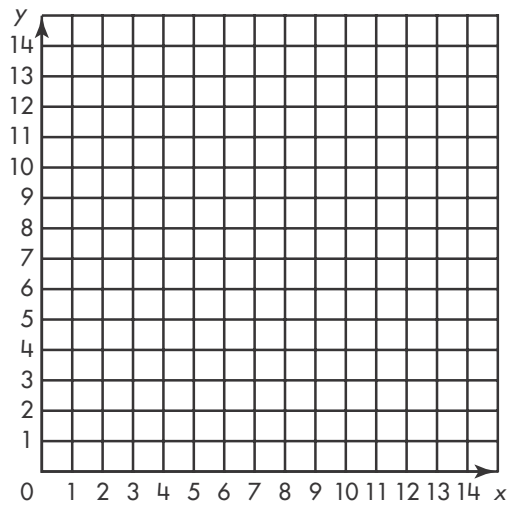
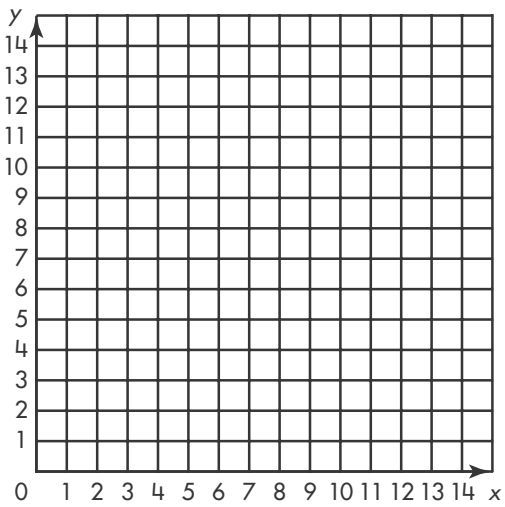
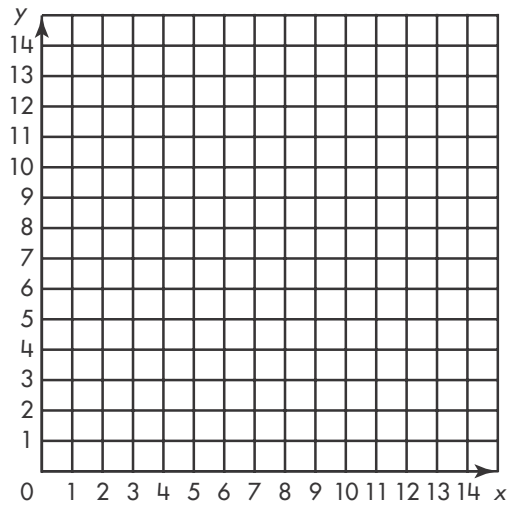
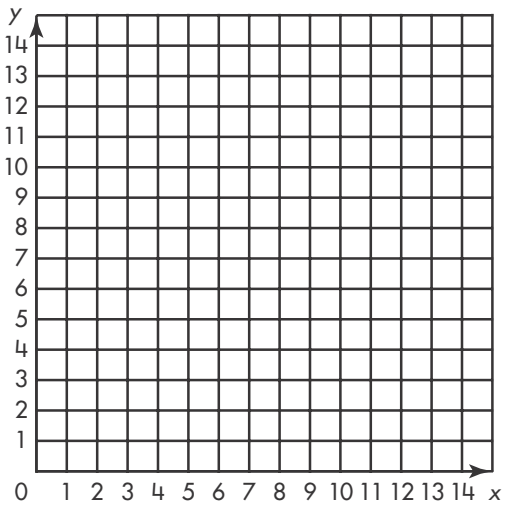
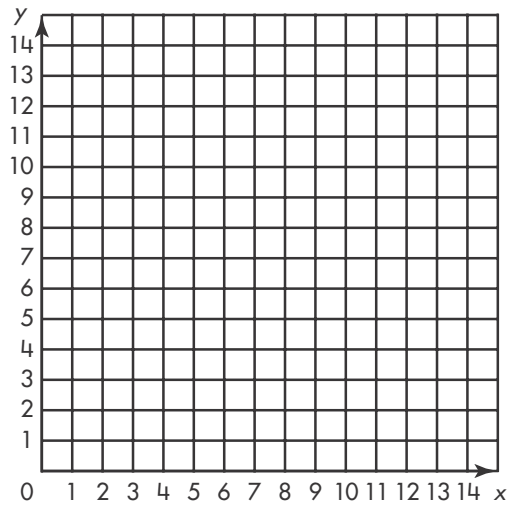
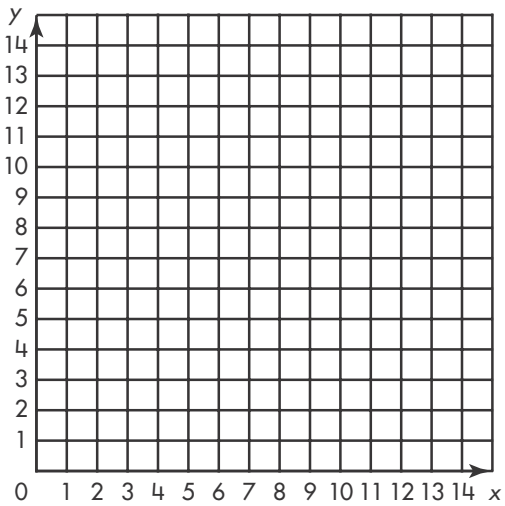

Name _____

1	2	3	4	5	6	7	8	9	10
11	12	13	14	15	16	17	18	19	20
21	22	23	24	25	26	27	28	29	30
31	32	33	34	35	36	37	38	39	40
41	42	43	44	45	46	47	48	49	50
51	52	53	54	55	56	57	58	59	60
61	62	63	64	65	66	67	68	69	70
71	72	73	74	75	76	77	78	79	80
81	82	83	84	85	86	87	88	89	90
91	92	93	94	95	96	97	98	99	100

Name _____

×	1	2	3	4	5	6	7	8	9	10	11	12
1	1	2	3	4	5	6	7	8	9	10	11	12
2	2	4	6	8	10	12	14	16	18	20	22	24
3	3	6	9	12	15	18	21	24	27	30	33	36
4	4	8	12	16	20	24	28	32	36	40	44	48
5	5	10	15	20	25	30	35	40	45	50	55	60
6	6	12	18	24	30	36	42	48	54	60	66	72
7	7	14	21	28	35	42	49	56	63	70	77	84
8	8	16	24	32	40	48	56	64	72	80	88	96
9	9	18	27	36	45	54	63	72	81	90	99	108
10	10	20	30	40	50	60	70	80	90	100	110	120
11	11	22	33	44	55	66	77	88	99	110	121	132
12	12	24	36	48	60	72	84	96	108	120	132	144

Name _____

- 1. (A) (B) (C) (D)
- 2. (A) (B) (C) (D)
- 3. (A) (B) (C) (D)
- 4. (A) (B) (C) (D)
- 5. (A) (B) (C) (D)
- 6. (A) (B) (C) (D)
- 7. (A) (B) (C) (D)
- 8. (A) (B) (C) (D)
- 9. (A) (B) (C) (D)
- 10. (A) (B) (C) (D)
- 11. (A) (B) (C) (D)
- 12. (A) (B) (C) (D)
- 13. (A) (B) (C) (D)
- 14. (A) (B) (C) (D)
- 15. (A) (B) (C) (D)
- 16. (A) (B) (C) (D)
- 17. (A) (B) (C) (D)
- 18. (A) (B) (C) (D)
- 19. (A) (B) (C) (D)
- 20. (A) (B) (C) (D)
- 21. (A) (B) (C) (D)
- 22. (A) (B) (C) (D)
- 23. (A) (B) (C) (D)
- 24. (A) (B) (C) (D)
- 25. (A) (B) (C) (D)
- 26. (A) (B) (C) (D)
- 27. (A) (B) (C) (D)
- 28. (A) (B) (C) (D)
- 29. (A) (B) (C) (D)
- 30. (A) (B) (C) (D)
- 31. (A) (B) (C) (D)
- 32. (A) (B) (C) (D)
- 33. (A) (B) (C) (D)
- 34. (A) (B) (C) (D)
- 35. (A) (B) (C) (D)
- 36. (A) (B) (C) (D)

Name _____

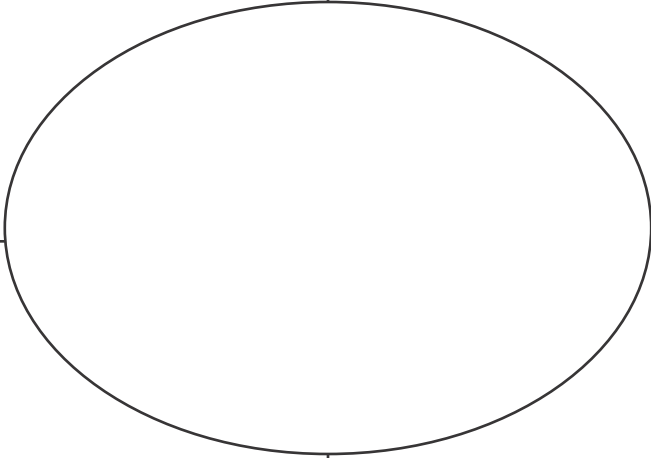
Definition	Characteristics
	
Examples	Non-Examples

Name _____

New Word	What It Means

Name _____

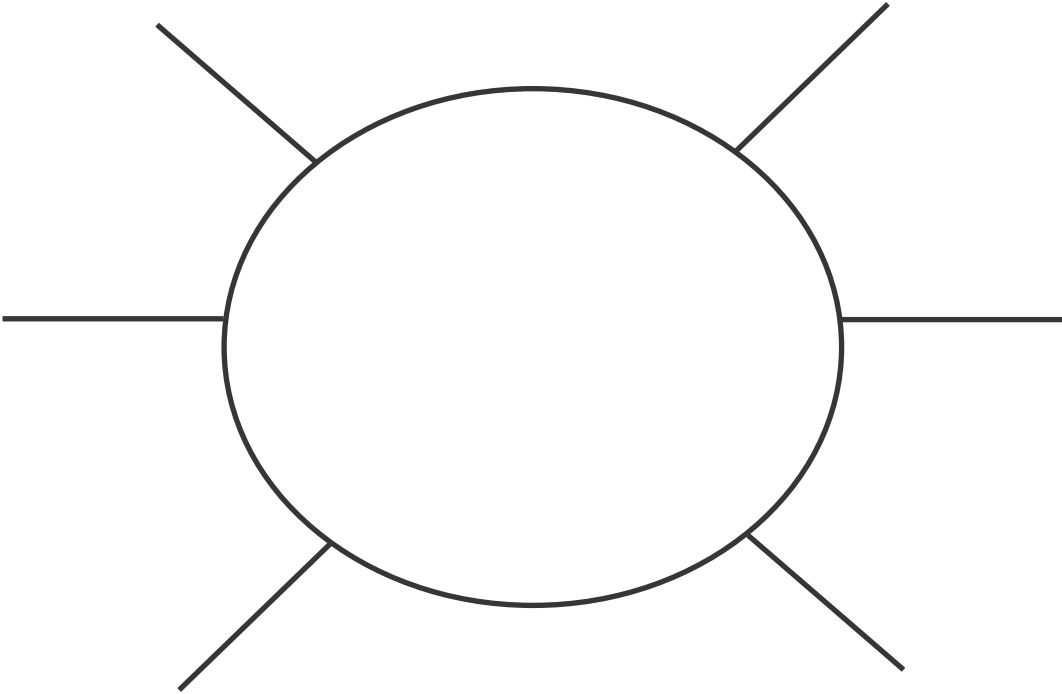

Name _____

New Symbol

What It Means:

New Shape

Name and Attributes:

Name _____

Put a ✓ in the circle if your answer is correct.
Put an ✗ in the circle if your answer is not correct.
Shade boxes where all circles are marked with a ✓.





Multiply Multi-Digit Whole Numbers						
Fluency Subskills	Fluency Practice/Assessment					
	1	2	3	4	5	6
A Multiply Two Two-Digit Numbers	1 ○	1 ○	1 ○	1 ○	1 ○	1 ○
	2 ○	2 ○	2 ○	2 ○	2 ○	2 ○
	3 ○	3 ○	3 ○	3 ○	3 ○	3 ○
	4 ○	4 ○	4 ○	4 ○	4 ○	4 ○
B Multiply Three-Digit Numbers by Two-Digit Numbers	5 ○	5 ○	5 ○	5 ○	5 ○	5 ○
	6 ○	6 ○	6 ○	6 ○	6 ○	6 ○
	7 ○	7 ○	7 ○	7 ○	7 ○	7 ○
	8 ○	8 ○	8 ○	8 ○	8 ○	8 ○
C Multiply Four-Digit Numbers by Two-Digit Numbers.	9 ○	9 ○	9 ○	9 ○	9 ○	9 ○
	10 ○	10 ○	10 ○	10 ○	10 ○	10 ○
	11 ○	11 ○	11 ○	11 ○	11 ○	11 ○
	12 ○	12 ○	12 ○	12 ○	12 ○	12 ○
D Multiply Across Zeros	13 ○	13 ○	13 ○	13 ○	13 ○	13 ○
	14 ○	14 ○	14 ○	14 ○	14 ○	14 ○
	15 ○	15 ○	15 ○	15 ○	15 ○	15 ○
	16 ○	16 ○	16 ○	16 ○	16 ○	16 ○

Name _____

Self-Assessment Tool

I am on the road to understanding...

Mark an X on the road to show where you are.

 I don't understand.	 I understand a little.	 I think I understand.	 I really understand!
<hr/> <hr/> <hr/>			

Road to Success

Explain the choice you made above.

Name _____



3-ACT MATH Recording Sheet

ACT 1

1. What questions do you have?



Brainstorm

2. Predict a reasonable answer to the Main Question. Explain your prediction.



Prediction

ACT 2

3. What information do you need to answer the Main Question?



4. Show how you can find the answer to the Main Question.



ACT 3

5. What is the answer shown in the video?



6. Does your answer match the Act 3 video? If not, what is one reason that could explain the difference?



SEQUEL

7. Show how you would answer the Sequel.

Solve & Share Observation Tool

SOLUTION STRATEGIES	QUESTIONS TO ASSESS AND MOVE THINKING FORWARD	WHO AND WHAT	SELECT AND ORDER
<p>Anticipate List likely solution strategies.</p> <p>Monitor Add any other strategies as you observe students.</p>	<p>Ask assessing questions Assess what students know and can do.</p> <p>Ask advancing questions Move students' thinking forward.</p>	<p>Record List students that used each strategy.</p>	<p>Select Circle presenters.</p> <p>Order Number presentations.</p>
<p>Save student work Keep a sample of each strategy for next year.</p> <p>Save this sheet Cover columns 3 and 4 with a sticky note to write on next year.</p>	<p>Problem Ask questions to see if students understand the problem.</p> <p>Strategy Ask what students did.</p> <p>Convincing Ask for justifications.</p> <p>Extending Ask for other strategies.</p>	<p>Plan ahead Which 2 or 3 strategies will you ask students to present?</p>	<p>Select Varied strategies</p> <p>Order Concrete to abstract; from old ideas to new</p>

DISCUSS SOLUTION STRATEGIES AND KEY IDEAS

Restate and comment Ask students to critique the reasoning of others.

Connect strategies Ask students to compare strategies.

Connect to prior knowledge and to new ideas Use students' work to make these connections explicit.